

Little GIANT[®]

Pump Company

1 SERIES



Features

- Epoxy coated die-cast aluminum housing
- Oil-filled motor
- 7.4' maximum lift
- 70 watts
- 1/4" MNPT discharge
- Thermal overload protection
(except 501003)
- For submersible use only

Construction

- Motor — 1/150 HP Oil Filled
- Intermittent Liquid Temp. up to — 120° F
- Intake — N/A
- Discharge — 1/4" MNPT
- Housing — Epoxy coated cast aluminum
- Cover — Epoxy coated cast aluminum
- Volute — Polypropylene
- Impeller — Polypropylene
- Shaft Seal — Nitrile
- Screen — Polypropylene

Small submersible oil-filled pump with epoxy coated cast aluminum housing. For commercial, industrial and home applications including statuary fountains, water displays, air conditioners, machine tool coolants, and many other applications where liquid must be transferred or recirculated. This compact 205 GPH pump features a 1/4" MNPT discharge, 7.4' shut-off head capability, and screened inlet.

Little Giant Pump Co.

1 SERIES

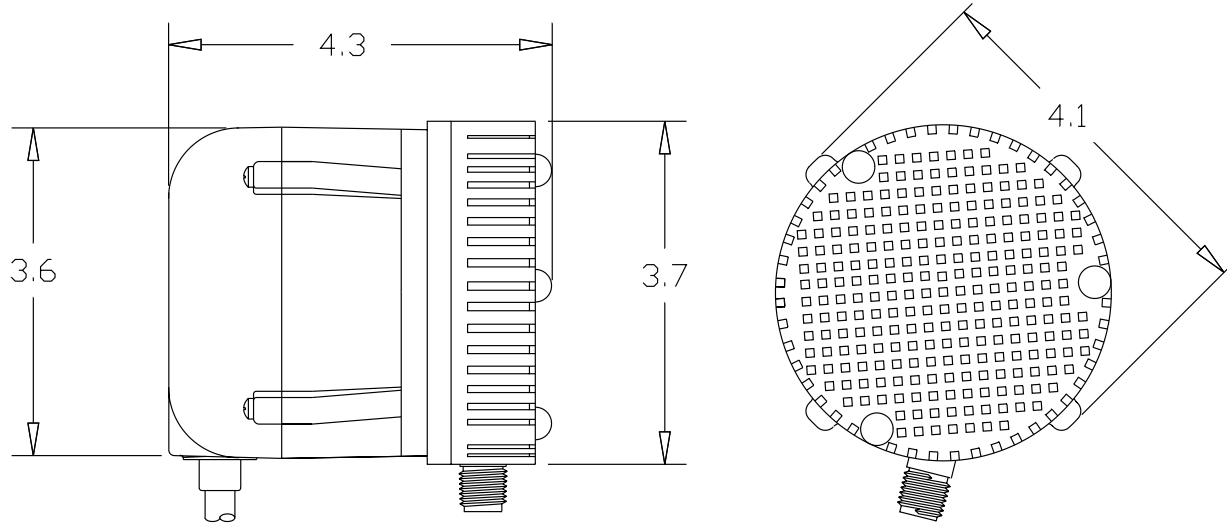

Specifications

Model No.	Item No.	Discharge Size	Listing(s)	HP	Volts	Hertz	Amps	Watts	Performance (GPH @ Head)			Shut Off		Pwr. Cord (ft)	Weight (Lbs.)
									1'	3'	5'	Feet	PSI		
1	501003	1/4" MNPT	UL	1/150	115	60	1.1	70	205	168	120	7.4	3.2	6	3.50
1	501500	1/4" MNPT		1/150	127	60	1.1	70	205	168	120	7.4	3.2	6	3.50
1-T	501086	1/4" MNPT	UL/CSA	1/150	115	60	1.1	70	205	168	120	7.4	3.2	10	3.67
1-Y	501016	1/4" MNPT	UR	1/150	230	50/60	.6/4	70	205	168	120	7.4	3.2	12	3.83

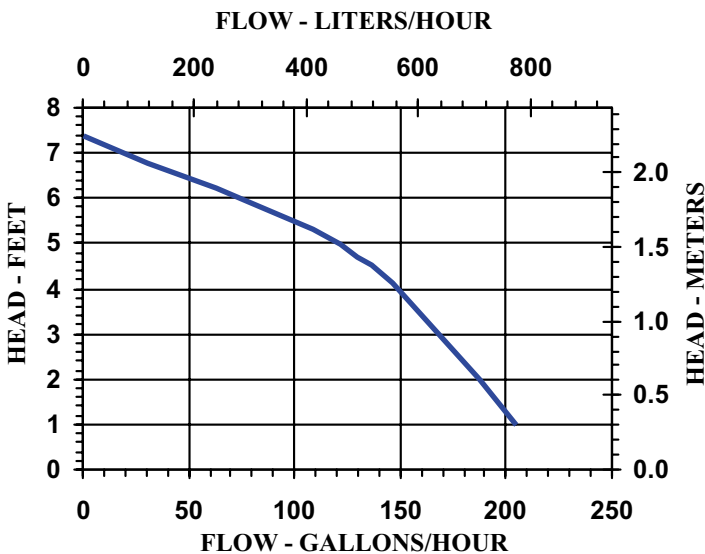

Replacement Parts

Volute	101350
Impeller	101441
Screen	101901
Elbow	943070

Little Giant Pump Co.
 PO Box 12010
 Okla. City, OK 73157
 Phone: 405.947.2511
 Fax: 405.228.1550
www.LittleGiantPump.com